



# BURST FIRED AC ENERGY REGULATOR 110-230V AC     16A

## ZVS 16DV

X10249

### INTRODUCTION

The ZVS 16DV is a dual voltage, 16A enclosed compact energy regulator. It provides manual proportional power control to resistive loads by using variable bursts of energy. The burst firing circuit provides trigger pulses coincident with the mains polarity crossover, ensuring complete sine wave cycles are passed through to the resistive load. This prevents fast changes in load current and inhibits radio frequency interference (RFI), which is normally associated with switches, relays and phase angle fired triacs or similar devices. The output is in block bursts, with a full 0 to 100% range.

### APPLICATIONS

Virtually all resistive heating loads including ovens, furnaces, hot plates, extruders, moulders, space heating, boilers, dryers, soldering pots and irons, heating tapes, stress relieving, smelters and heating mantles.

### FEATURES

- Input voltage range suitable for 110V to 230V ac
- Load rating range - resistive, from 0.1 to 3.7kW @ 230V and 0.1 to 1.8kW @ 110V ac
- High surge 26A power device
- No remote filter requirements - Zero Voltage Switching control
- Wire protective screw fixing terminal block connections

RoHS Compliant  
Directive  
2002/95/EC



### INSTALLATION

#### DIMENSIONS AND CONNECTIONS

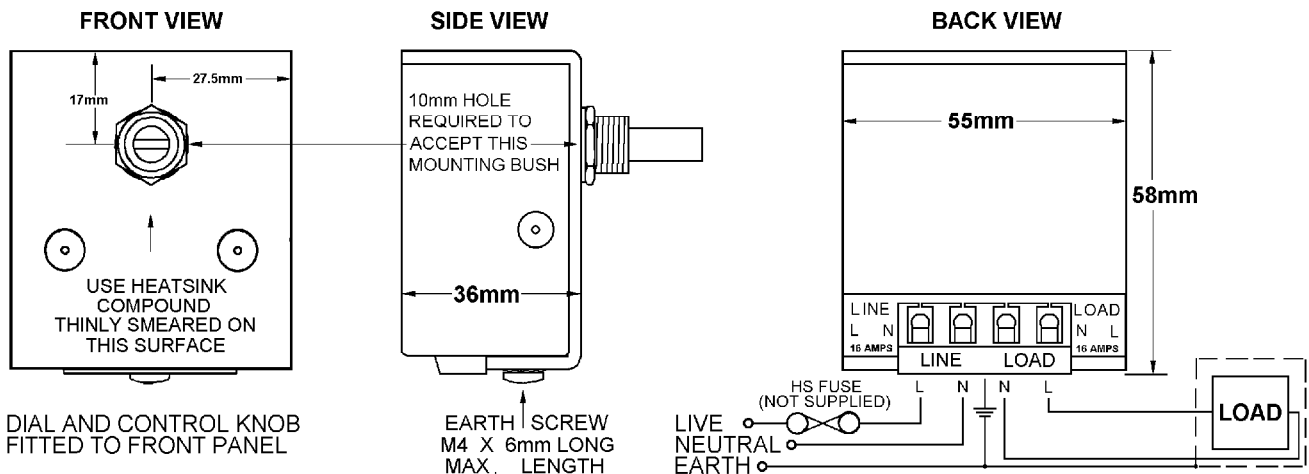

DIAL AND CONTROL KNOB FITTED TO FRONT PANEL

WARNING LIVE TERMINALS (SWITCH OFF MAINS BEFORE COMMENCING ANY SERVICING WORK)

## INSTALLATION

## COOLING REQUIREMENTS

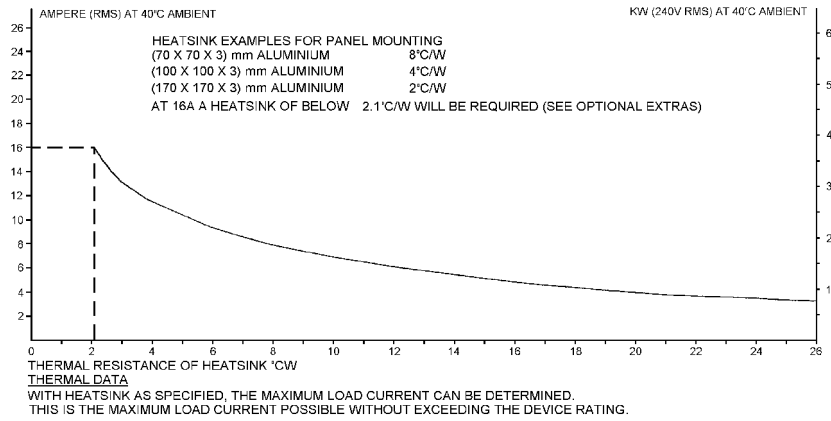

## SPECIFICATIONS

Maximum RMS on-state current	16A	I <sup>2</sup> t for fusing	128 A <sup>2</sup> s
Peak one cycle surge current	200A	Weight (approx)	105g
Maximum supply voltage +/-10% @ 50/60Hz	230V	Maximum c.s.a. cable entry	2.5mm <sup>2</sup>
Minimum supply voltage +/-10% @ 50/60Hz	110V	<i>further dimensions</i>	
Maximum peak repetitive voltage	600V	Shaft diameter (1/4 inch)	6.3mm
Maximum Power consumption	6W	Shaft projection from bush	13mm
Operating and storage temperature range	-20 to +85°C	Bush length	7mm
Isolation voltage	2500V rms	Fixing hole diameter	10mm

## FUSING:

It is recommended to use semiconductor (fast acting) type fuses or circuit breakers (Semiconductor - MCB) for unit protection. On initial 'switch on' some loads may need an increased Factor of Safety (F of S) for unit and/or device protection. (See SRA Datasheet for further information)

## CE MARKING

This product family carries a "CE marking". For information see recommendation section and contact our sales desk. (See Declaration of Conformity)

## RECOMMENDATION

Other documents available on request, which may be appropriate for your applications.

CODE	IDENTITY	DESCRIPTION
X10229	RFI	Filtering recommendation - addressing EMC Directive
X10213	ITA	Interaction, uses for phase angle and for burst fire control.
X10255	SRA	Safety requirements - addressing the Low Voltage Directive (LVD) including :- Thermal data/cooling; "Live" parts warning & Earthing requirements; Fusing recommendations.
AP02/4	COS	UAL Conditions of sale.

**NOTE** It is recommended that installation and maintenance of this equipment should be done with reference to the current edition of the I.E.E. regulations (BS7671) by suitably qualified/trained personnel. The regulations contain important requirements regarding safety of electrical equipment. (For International standards refer to I.E.C directive IEC 950)

**ORDER CODE:** *State product description* **ZVS 16DV**

**OPTIONAL EXTRAS:** Standard Knob; ZVS Dial, Heatsink compound



## UNITED AUTOMATION LIMITED

1Southport Business Park  
 Kew  
 Southport, PR8 4HQ  
 ENGLAND

Tel: 0044 (0) 1704 – 516500 Main  
 Tel: 0044 (0) 1704 – 516516 Sales  
 Fax: 0044 (0) 1704 – 516501  
 Enquiry@united-automation.com  
 www.united-automation.com

Page No. 2 of 2 Issue 2

Date 30/11/99



015

This document was created with Win2PDF available at <http://www.win2pdf.com>.  
The unregistered version of Win2PDF is for evaluation or non-commercial use only.  
This page will not be added after purchasing Win2PDF.